



Educational Brief

International Space Station Crew Return Vehicle: X-38

The International Space Station (ISS) will provide the world with an orbiting laboratory that will have long-duration micro-gravity experimentation capability. The crew size for this facility will depend upon the crew return capability. The first crews will consist of three astronauts from Russia and the United States. The crew is limited to three because the Russian Soyuz vehicle that will remain docked to the ISS can only hold three people. It is imperative that the crew members be able to return to Earth if there is a medical emergency or if other complications arise. In development at this time is a Crew Return Vehicle that will be able to hold up to seven crew members. This will allow the full complement of seven astronauts to live and work onboard the ISS.

The Crew Return Vehicle, or X-38, uses a lifting body concept originally developed by the U.S. Air Force in the mid-1960s. These wingless lifting bodies attain aerodynamic stability and lift from the shape of the aircraft. Lift results from more air pressure on the bottom of the body than on the top. Following the jettison of a deorbit engine, the X-38 will glide from orbit and use a steerable, parafoil parachute for its final descent to landing. The high speeds at which lifting body aircraft operate make it dangerous to land. The parafoil is used to slow the vehicle down and make it safer. Its landing gear consists of skids rather than wheels. The skids work like sleds so the vehicle will glide to a stop on the ground.

Both the shape and size of the X-38 are different from the traditional Space Shuttle. The Crew Return Vehicle can fit into the payload bay of the Space Shuttle. This does not, however, mean it is small. The X-38 weighs 10,660 kg and is 9.1 meters long. The battery system, which will keep its charge for nine hours, is used for power and life support. If the Crew Return Vehicle is needed, it will only take two to three hours for it to reach Earth.

The parafoil parachute, employed for landing, is derived from technology developed by the U.S. Army. This massive parafoil deploys in stages for optimum performance. A drag chute will be released from the rear of the X-38. This drag chute is used to stabilize and slow the vehicle down. The giant parafoil—which has an area of 687 square meters—is then released. It will open in four stages (a process called staging). While the staging process only takes 45 seconds, it is important for a successful chute deployment. Staging prevents high-speed winds from tearing the parafoil.

The spacecraft's landing is completely automated. Mission Control sends coordinates to the onboard computer system. This system will also use wind sensors and the Global Positioning System (a satellite-based coordinate system) to coordinate a safe trip home. Since the Crew Return Vehicle was designed with medical emergencies in mind, it makes sense that the vehicle can find its way home automatically in the event that crew members are incapacitated or injured. If there is a need, the crew will have the capability to operate the vehicle by switching to the backup systems.

Some of the technologies used for the creation of the X-38 have come from many places and are not new. Combining these technologies with new ideas and capabilities has created a vehicle that will be tasked with the mission of carrying home the crew of the ISS if there is an onboard emergency. By utilizing technologies from the 1960s in the 1990s and by being fast, safe, and dependable, the Crew Return Vehicle will provide peace of mind to all those who will live and work onboard the ISS.

Construct A Parafoil

Objectives:

To construct a parafoil similar to the one that will be used for the X-38.
To test the parafoil's performance capabilities.

Science Standards

Grades 5-8

Physical Science: Motions and forces
Science and Technology: Abilities of technological design

Mathematical Standards

Grades 5-8

Measurement
Geometry
Computation and estimation

Materials:

Paper pattern*
Sewing thread
Cellophane tape
Glue stick
Weights (different sized metal washers and nuts)
Metric ruler
Scissors
Sharp knife
Cutting surface

Procedure:

1. Cut out the paper pattern for the parafoil.
2. Use the sharp knife to cut small slots for the tabs. It may be necessary to assist younger students with this step.
3. Prefold the parafoil on the dashed lines.
4. Insert the tabs marked "port" and "starboard" into their corresponding slots.
5. Hold the tab securely by taping them on the inside of the parafoil.
6. Fold the left and right sides of the parafoil together so that the flaps come together. Spread glue on the inside of the flaps and press them together.
7. Fold over the flap and glue it to the lower side of the center airfoil to hold it together.
8. Bend the port and starboard airfoils slightly downwards so that they join the center airfoil along the edges. Make sure the tabs are slipped inside the model for strength. Hold the airfoils together with a small amount of cellophane tape.
9. Attach two pieces of thread to the front and back of each side with a small piece of tape. Each thread should be 30 centimeters long.
10. Tie the ends of the threads together and then tie a weight to the ends.

Please take a moment to evaluate this product at http://ehb2.gsfc.nasa.gov/edcats/educational_brief. Your evaluation and suggestions are vital to continually improving NASA educational materials. Thank you.



Flight Testing:

1. Hold the parafoil off the floor and drop it. Observe how it flies.
2. Make adjustments to improve the parafoil's flight. Possible adjustments include:
 - Tying the weight higher up on the threads
 - Adjusting the flaps up or down
 - Using a heavier or lighter weight
 - Shortening or lengthening the front or back threads to change the angle of the parafoil to the vertical

Assessment:

Measure how far the parafoil glides when dropped from a given altitude. Graph the glide distance of the parafoil with different weights.

Extensions:

Compare and contrast the operation of a parafoil with a traditional parachute. Small parachutes can be made from circles cut from plastic grocery bags. Attach threads with tape and hang a weight from the ends.

* *The shaded small rectangles on the leading edge of the parafoil represent the open cells in the real parafoil that take in air so that the parafoil becomes rigid.*

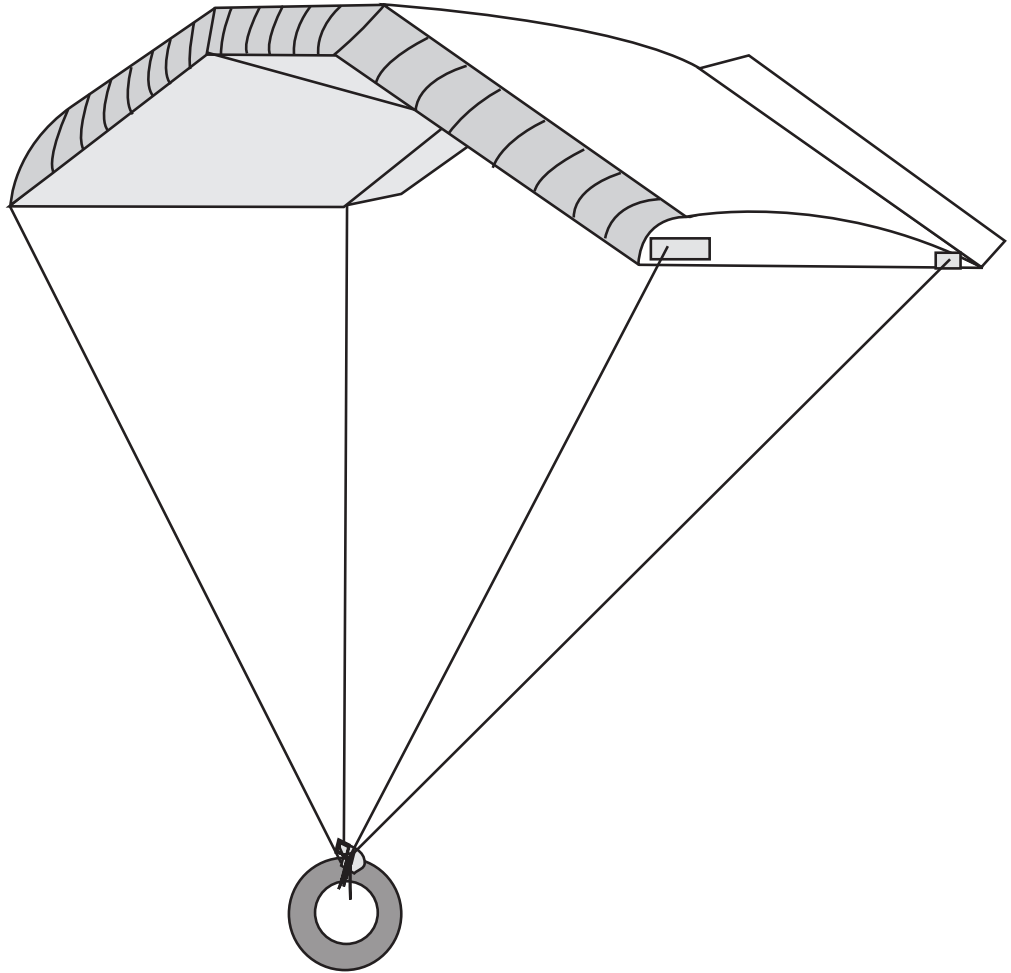

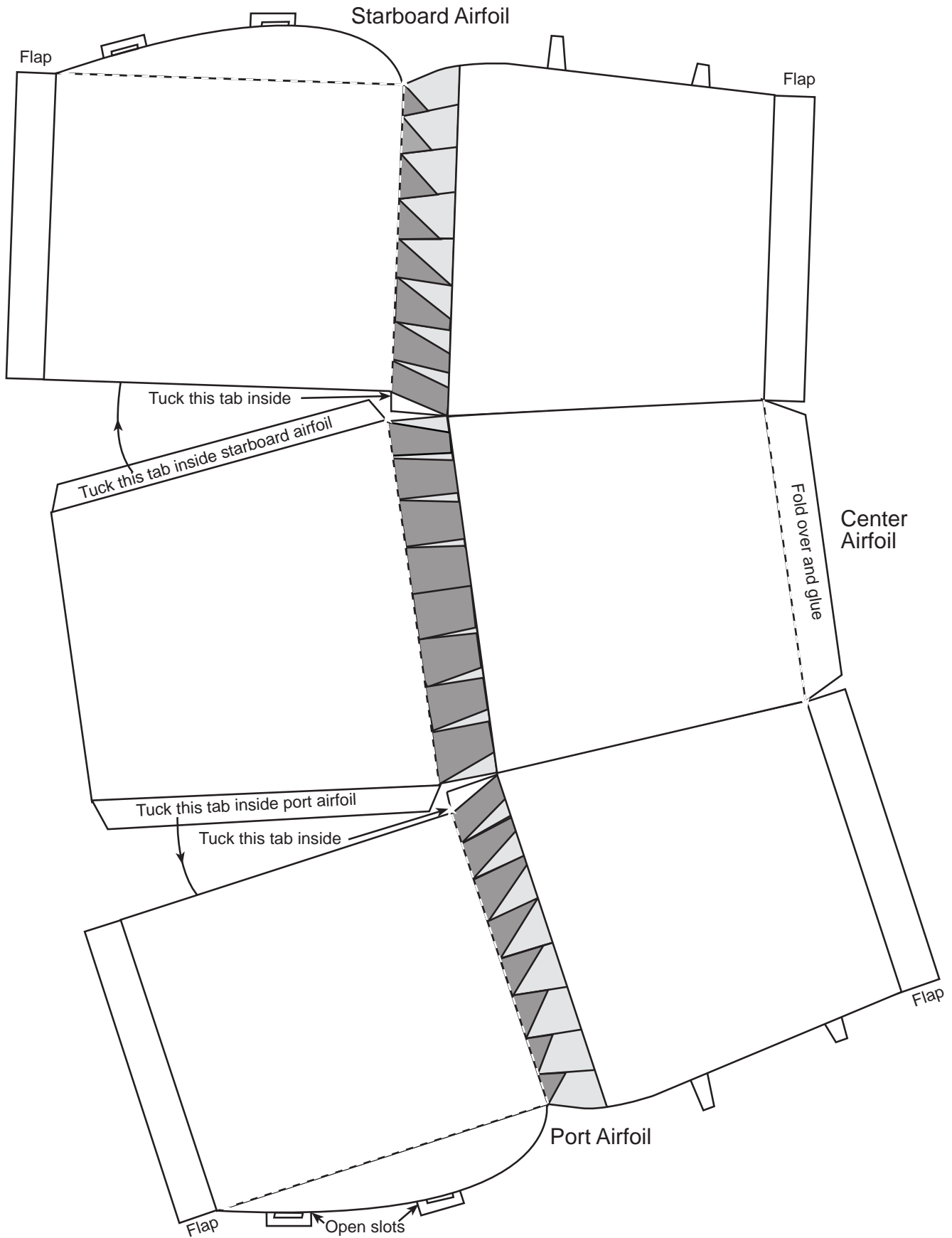

Note: Pattern may be enlarged.

